

Instructions for Installing HMI Cover

NOTE: Phillips Screwdriver or similar tool is required to install cover.

1. Place frame on a flat smooth surface and mark hole locations and panel opening.
2. Drill or cut holes 7/32 or #2 (.220 Dia) and opening accordingly. (Prior to mounting, clean surface and gasket of debris.)
3. Mount HMI Cover with supplied mounting hardware. Hardware applicable to mounting surface thickness of .059" - .250". Hardware torque specification 15 - 20 in-lbs.
4. Hardware kit includes:
 - 70-10321 quantity 10. 10-32 X 1 Pan Head Machine Screw.
 - 70-EMRWASHER quantity 10. Stainless Steel Washer Rivet.
 - 55-1032 quantity 10. Nut 10-32 With Nylon Insert.

Note: Part includes feature on latch that may be used to prevent unauthorized or unintentional opening of the latches. Padlock sold separately.

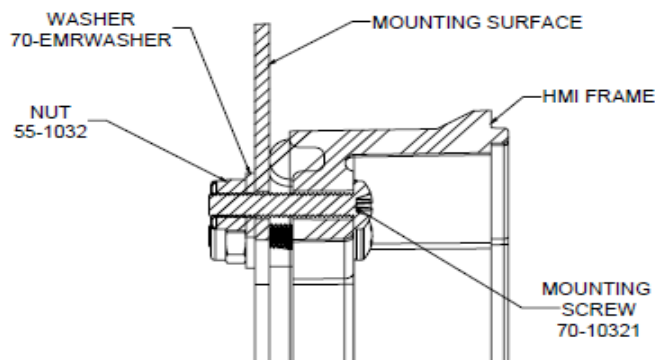

PART NUMBER	NUMBER OF KITS	MAX PANEL CUTOUT SIZE (IN.)		NUMBER OF FASTENERS NEEDED
		H	W	
H-X-YD7	1	8.47	6.69	8
H-X-YA7	1	10.47	8.69	8
H-X-YC7	1	12.49	10.71	10
H-X-YE7	1	14.49	12.71	10
H-X-YF7	2	18.49	14.71	18

May include extra hardware depending on HMI frame size.

